



Global marine engineering firm  
offering a range of services in  
the maritime sector.



# WELCOME

**CONSULTING  
DESIGN ENGINEERING  
PROJECT MANAGEMENT  
ON SITE SUPPORT**

**Certified**

ISO 9001:2015

ISO 27001:2013





## TABLE OF CONTENT

01. The Company	03
02. Excellence for you	04
03. Our Services	05
04. Our Company	19
05. Accreditations & Affiliations	20
06. Stats	21
07. Projects Floated	22



# THE COMPANY

---

## ABOUT US

We are a professional Ship & Offshore design engineering related service provider covering entire gamut of ship design spiral and onsite production support. Based on the west coast of India along the pristine beaches of Goa our service philosophy incorporates the culture of listening to our customer, understanding their needs and providing highest level of quality professional & service to his satisfaction. By following the latest technology trends we make use of the most advance software to meet any complex engineering requirement of the Shipbuilding & Offshore Industry. We are Certified ISO 9001:2015, ISO 27001:2013.



# EXCELLENCE FOR YOU

## MAKING YOUR PROJECT FLOAT!



### 'Designed to Fit' Design Packages

Ensures higher profitability during production due of efficient use of material, build strategy & component traceability



### Live Project Management

- Constant online progress review for clients via project management interface
- Online model sharing for error free design and excellent coordination



### Use of Advance Software

- Complex situations are solved with fundamentally strong yet simple solutions



# OUR SERVICES



## CONCEPT DESIGN

Depending on the owner's requirement Buoyancy Consultants by way of Feasibility studies & concept evaluations. Checks the viability of the project keeping in mind the performance and operational risk analysis.



## INITIAL DESIGN

Based on the Concept design, Buoyancy Consultants can provide all necessary initial design documentation that forms a part of the tender documentation that may be used for entering contract with shipyards.

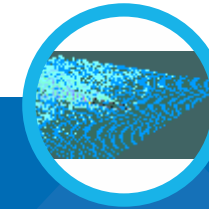

## BASIC DESIGN

Covering the entire design spiral, Buoyancy Consultants can start with the owner's mission requirement and generate the cost estimates for construction of vessels.



### CLASSIFICATION SOCIETIES

We liaise with various classification societies for necessary approvals like:-

- Indian Register of Shipping
- ABS
- Bureau Veritas
- DNVGL



### SOFTWARE EXPERTISE

Being platform independent we can use Specialised 3D design solutions like:-

- Cadmatic Marine
- Aveva Marine
- Smart Marine 3D
- Ship Constructor
- FORAN
- Maxsurf



### OUR FOCUS

- Highest Quality
- On Schedule
- Cost Effective
- Customer Experience



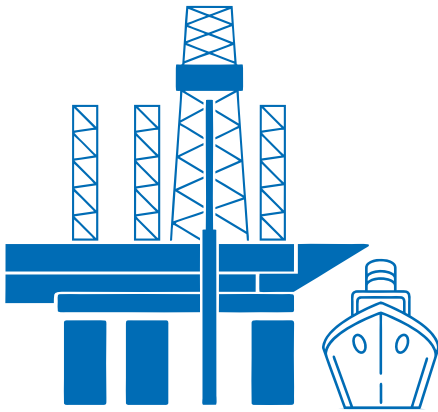

As our client, when you need your project charted out, talk to us. With Buoyancy Consultants your project is in good hands. Quality Basic design and Detail Engineering Service for production is part of what we do. From Optimization to Consultancy we got it all covered. That's because at Buoyancy Consultants we abide by our code : Making Your Project Float !



## CLASS DRAWINGS/ STATUTORY PLANS

Being well versed with different classification societies standards, we are in a position to deliver required class drawing layouts covering General Arrangement plans to Safety plans in line with SOLAS rules.



## DETAIL DESIGN

Buoyancy Consultants can start from scratch building the detail model of any kind of project with rule based quality check process and generate production drawings and various customizable outputs as per client requirement.

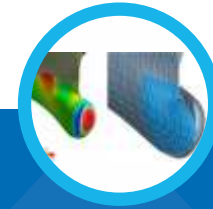

## RETROFIT/CONVERSIONS

Buoyancy Consultants team have experienced in working on any conversion proposal in order to meet new regulations/conventions, equipped the vessel with latest advance equipment's, improve the cargo capacity or carry new type of cargo, reduced emissions, reduce fuel consumptions, improve stability and speed of the vessel.





# OUR SERVICES

---

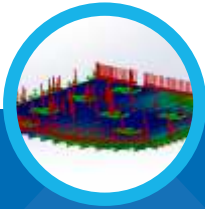

## ANALYSIS

Buoyancy Consultants team with the use of advanced FEM computing facility and simulations software available with us, we provide analysis of ships behaviour in sea for different loading conditions determining its stability, structural strength assessment, scantling checks, buckling, static and dynamic, torsional, flexure, thermal and vibration analysis.



## PROJECT MANAGEMENT

With project management Buoyancy Consultants cater's to ship owners by providing a one stop destination for its design and site supervision requirements.



## LASER SCANNING

Buoyancy Consultants use this technique for collecting high-density 3-D data to create digital models of complex entities. Using the highly accurate 3-D scan cloud point data CAD models of as-built structures is intelligently modelled.





“Working with Buoyancy Consultants we found a team that was an extension of our own. Knowledgeable, Professional and Thorough. They were able to deliver on time, provide insights into design efficiencies. Buoyancy Consultants is our first choice on these projects.”



## Offshore Projects , UAE



### ONSITE SERVICES

Buoyancy Consultants offer extensive onsite services and provide comprehensive and integrated solutions to the client covering a wide range of services from supervision for new structures, conversion and repairs, sea trials, inclining experiment and Life extension surveys.



### MEP

Our capabilities in Mechanical, Electrical & Plumbing (MEP) are built around providing feasible and economically viable designs. The spectrum of services offered by Buoyancy Consultants encompasses MEP Drafting and Modelling Services, HVAC Design Services, HVAC Duct and Piping Design and Plumbing Design Services.



### ENGINEERING CONSULTANCY

Our General Engineering Consultancy aim in providing solutions to client projects in various disciplines of engineering. Using CAD/CAM/CAE software.

“Buoyancy Consultants and their team never fail to impress. We’ve worked on multiple projects and their attention to detail, solution approach and response time is world class. Particularly appreciate their concept clarity process and really listening to what our firm needed. Great Job Team Buoyancy!”

**Design Engineering Co. USA**

“We appreciate the work Buoyancy Consultants does. Their approach and work ethic makes them the obvious choice. They have a very professional team. Makes working with them very easy. They also have very good design ideas for our projects.”

**Ship Design Co. Netherlands:**



# CONCEPT DESIGN

The company has an outstanding hull-form design and development and our naval architecture experience results in vessels that offer good sea-keeping ability, low resistance and high propulsive efficiency. Additionally, we look into the efficiency of hull by Hull Standardization procedure allowing us to provide efficient vessels in performance as well as enabling ease in construction.

With an intimate knowledge of naval architecture in the design of steel, aluminium and composite structures combined with state of the art computational software, Buoyancy Consultants has been responsible for some of the most advanced marine structures and can offer designs for the most challenging of structures.

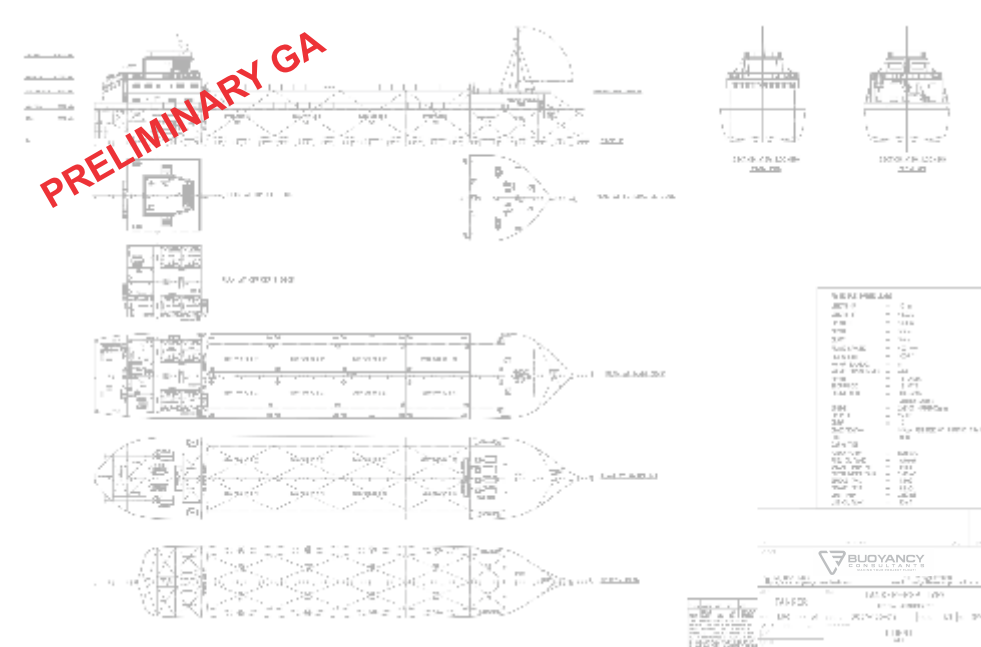
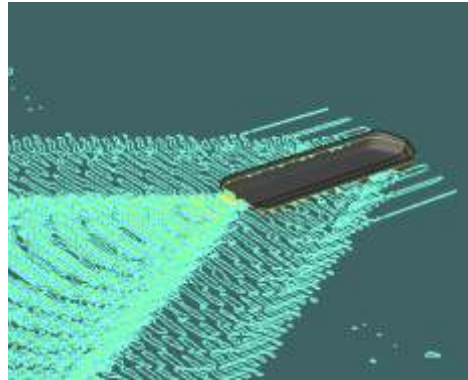

- 1 Determination of the principle particulars, design concept and artistic style
- 2 Lines plan
- 3 Preliminary Midship section Plan
- 4 Light ship weight calculations
- 5 Tonnage Calculations
- 6 Preliminary General Arrgt plan
- 7 Engine room arrgt plan
- 8 Determination of sea keeping and powering characteristics
- 9 Determination of the propulsion package selection basis:
  - Speed specifications
  - Quantity and capacity of various machinery
  - Equipment package
- 10 Preparation of outline Technical Specifications
- 11 Prebid design package services for tenders





1 Study of Owners requirement  
Supply/trade requirement/transport/speed/TEU

2 Concept Design calculation  
Setting up the constraints on L, B, D, T  
Selection of Main Parameters  
Defining stability Constraints

3 Concept General Arrangement

4 Concept Specification







**INDIA'S BIGGEST FLOATING CASINO**



# INITIAL & BASIC DESIGN

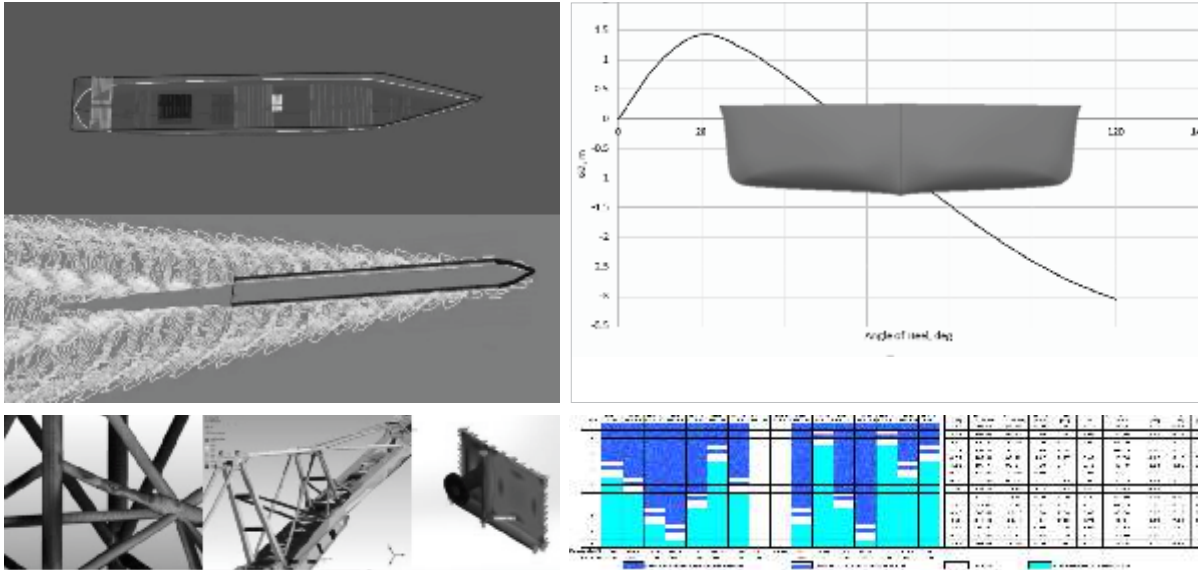

## NEW REQUIREMENTS FOR PANAMA CANAL TRANSIT

After class approval, all relevant drawings have to be submitted to the Panama Canal Authority (ACP) for acceptance, as only ACP itself is authorised to confirm compliance.

## EEDI & SEEMP

The Energy Efficiency Design Index (EEDI) was made mandatory for new ships and the Ship Energy Efficiency Management Plan (SEEMP) for all ships at MEPC 62 (July 2011) with the adoption of amendments to MARPOL Annex VI (resolution MEPC.203(62)), by Parties to MARPOL Annex VI

## BALLAST WATER MANAGEMENT PLAN

Feasibility study Basic Design and Detailed Design of Ballast Water Treatment System.

## CFD, FEA & Mooring Analysis

Applying Computational Fluid Dynamics Analysis and Finite Element Analysis for various ship and offshore assets, Mooring Analysis 4 point & 8 point & Sea Transportation Analysis, Lifting Analysis

## BASIC DESIGN

- Faired Lines plan & Hull Form
- General Arrangement Plan
- Technical Specifications
- Resistance/ Powering Calculations
- Class Approvals
- Subdivision & Capacity Plan
- Hydrostatic Data
- Shell Expansion Plan
- Various Class Drawings
- Scantling Calculations
- Stability Booklet –IMO, MARPOL, USCG, ISO, JG Code, Royal Navy, Australian NSCV, DNV etc.
- Safety Plan – LSA, FFA, etc.

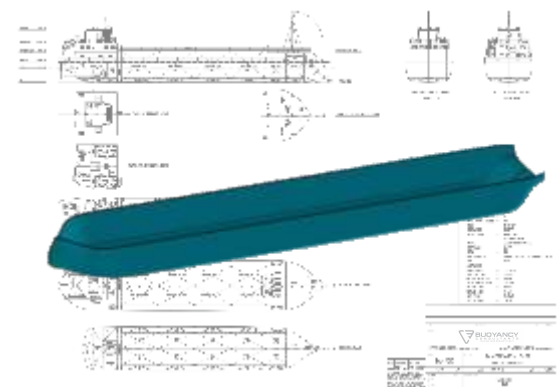

# DETAIL DESIGN

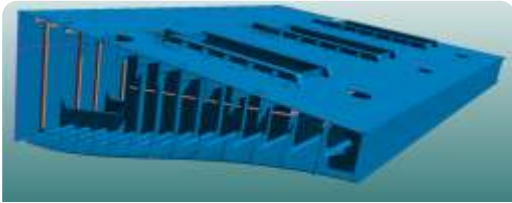

## OUR EXPERTISE IN STRUCTURE

- Lines production and hull form
- Shell plating and hull structure
- Nesting
- Assembly planning and sequencing
- Skid modeling for curved hull erection and block lifting plans
- Block drawings and reports / list
- Hull production information
- Bending templates
- Profile sketch and bending table
- Panel line drawings

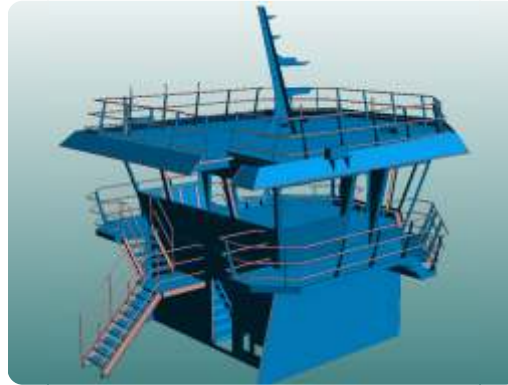

## OUR EXPERTISE IN HULL - OUTFIT

- Machinery foundations
- Stairways & ladder design
- Railings and protection cage
- Drip tray and other minor supports
- Portable tanks.
- Walkways & mast design.
- Necessary arrangement drawings
- Partlist / Bill of materials



## OUR EXPERTISE IN OUTFITTING

- Creation of project libraries
- Pipe, HVAC and cable tray engineering
- Equipment modeling
- Foundations and pipe supports
- Composite layout / arrangement drawings
- Isometric and spool sketches for pipe and HVAC
- Partlist / Bill of materials



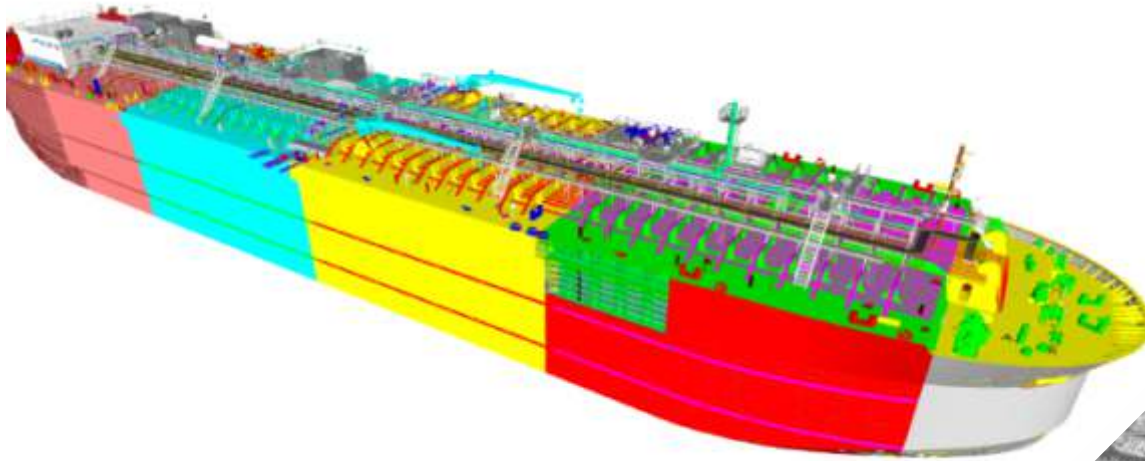

**WORLD'S LARGEST LNG PLANT**



**DETAILED COMPLEX LIQUIFIED AMMONIA TRANSPORT VESSEL**





# REPAIRS & CONVERSION

## RETROFIT

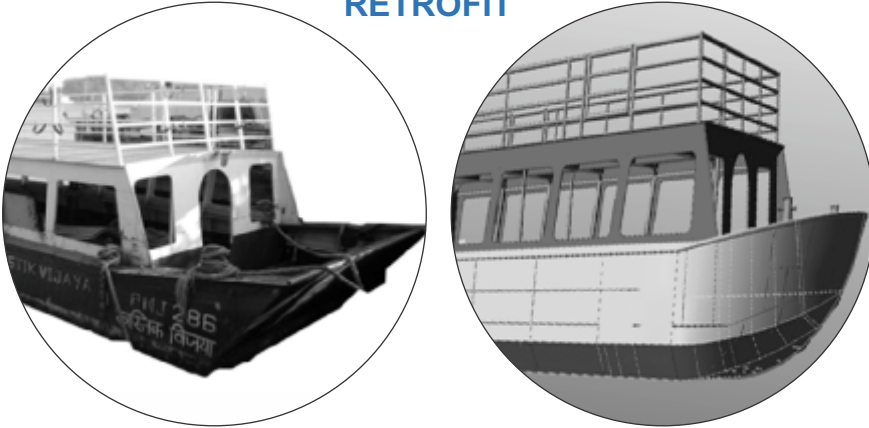

## CONVERSION



## MODIFICATION



## SERVICES:

- Assessment of Suitable Technology and Availability
- Ship Survey / Appraisal / Pre-planning / 3-D Scanning
- Feasibility Study Providing 3-D Modelling of Pre-selected System
- Modifications (Steel Modification, Piping Modification).
- Up-gradations & New Installations (hull Outfitting/Auxiliary Equipment's and Related Piping, Integrated and Independent Tanks).
- Efficiency Optimisation (Bulbous Bow, Main & Aux. Engines, Rudder, Propeller).
- Capacity Increase (deckhouse Elevation, Lengthening, Sponsons).
- Design Engineering (Class Package, Detail Design, Prod. Info. and As-built Documentation, Including Preparation and Submission of All Documentation Required for Class Approval).
- Technical Assistance Throughout Fabrication and Installation.
- Offshore( FPSO Conversion, Installation Vessel Conversion, Deep Sea Cranes, Rov Decks, Sps Upgrade).
- Upgrading Solutions for Owners, Operators and Yards
- Ballast Water Treatment
- Pre and Post Evaluation of Efficiency
- Fuel and Emissions Energy Efficiency Design Index (EEDI), Ship Energy Efficiency Management Plan (SEEMP)
- Retrofit as per new requirements for panama canal transit

# PROJECT MANAGEMENT



## SERVICES:

- Undertake new building projects with necessary assistance for shipyard selection, bidding & production supervision for ship owners.
- Shipyard layout design, drydock & berthing jetties for efficient operations of berthing, new building & repair projects.
- Site supervision to ensure production or repairs are up to the operations requirement.
- Onsite deputation for production quality inspections and site surveys.

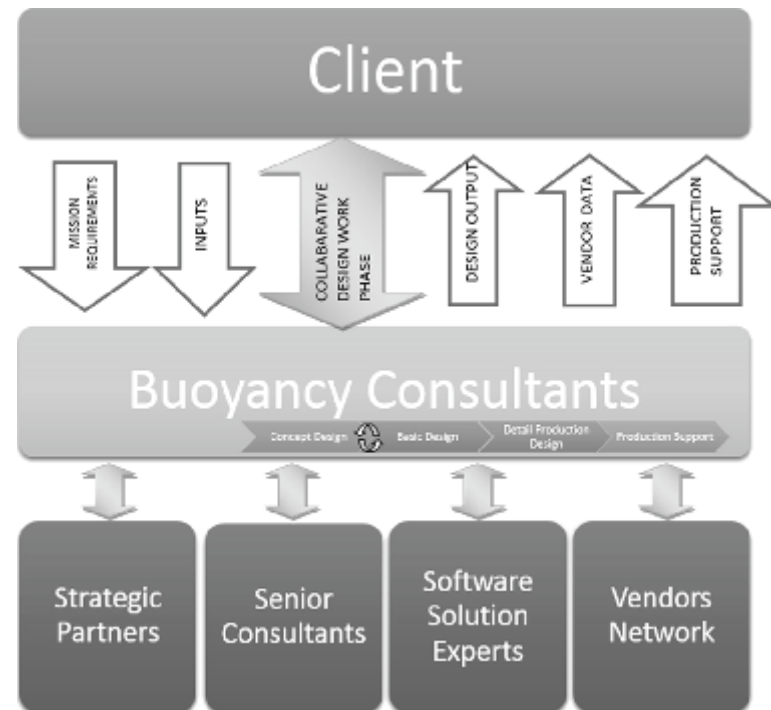

# LASER SCANNING

## SERVICES

- Refurbishment & Extensions
- Scan to BIM
- Oil & Gas Revamping projects
- Intelligent Modelling
- 2D drawing creation, validation & extraction
- Clash Checking
- Site Survey using Drone
- As-built Verification & Drawings
- P & ID, Isometric Drawings
- Tank Volume Calculations
- Actual construction progress tracking
- Architectural 3D Scanning

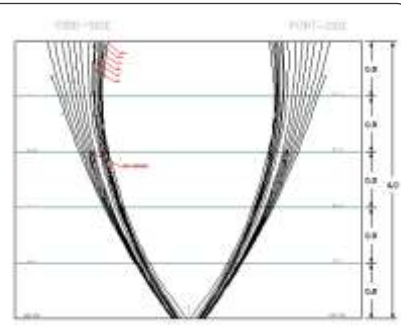
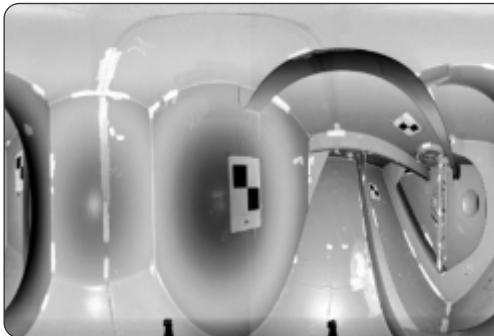



# ENGINEERING CONSULTANCY

## SERVICES

- Life conditional Assessment Surveys
- Industrial & Process Engineering
- Port & Logistics
- Site Surveys using Drone
- Yacht Compliance
- Feasibility Studies
- Detailed Engineering
- Pre-project Reports and Technical Studies
- Design Verification
- Virtual Reality Projects



Life conditional Assessment Survey of TUG

## In-house Software Expertise



Virtual Reality Cave Design

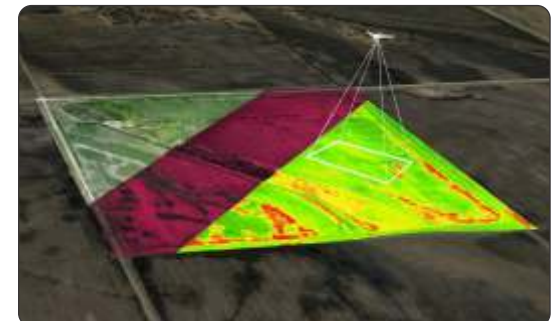

Site Survey using Drone



# OUR COMPANY

**BRIEF HISTORY:** After over a decade of working in the International Shipping Industry, Buoyancy Consultants and Engineering LLP began in 2013, with Ms. Pratibha Sawant and Mr. Ramniwas Mourya as its cofounders. A humble yet highly skilled group soon emerged under their guidance. Fast forward 4 years, its team of 45 is spread across 4 International and 2 National ones. In 2016 B.C.E. LLP won 3 awards and in 2017 was awarded the 'Best Marine Engineering Firm' By BuildArchitecture U.K.

## Company Timeline

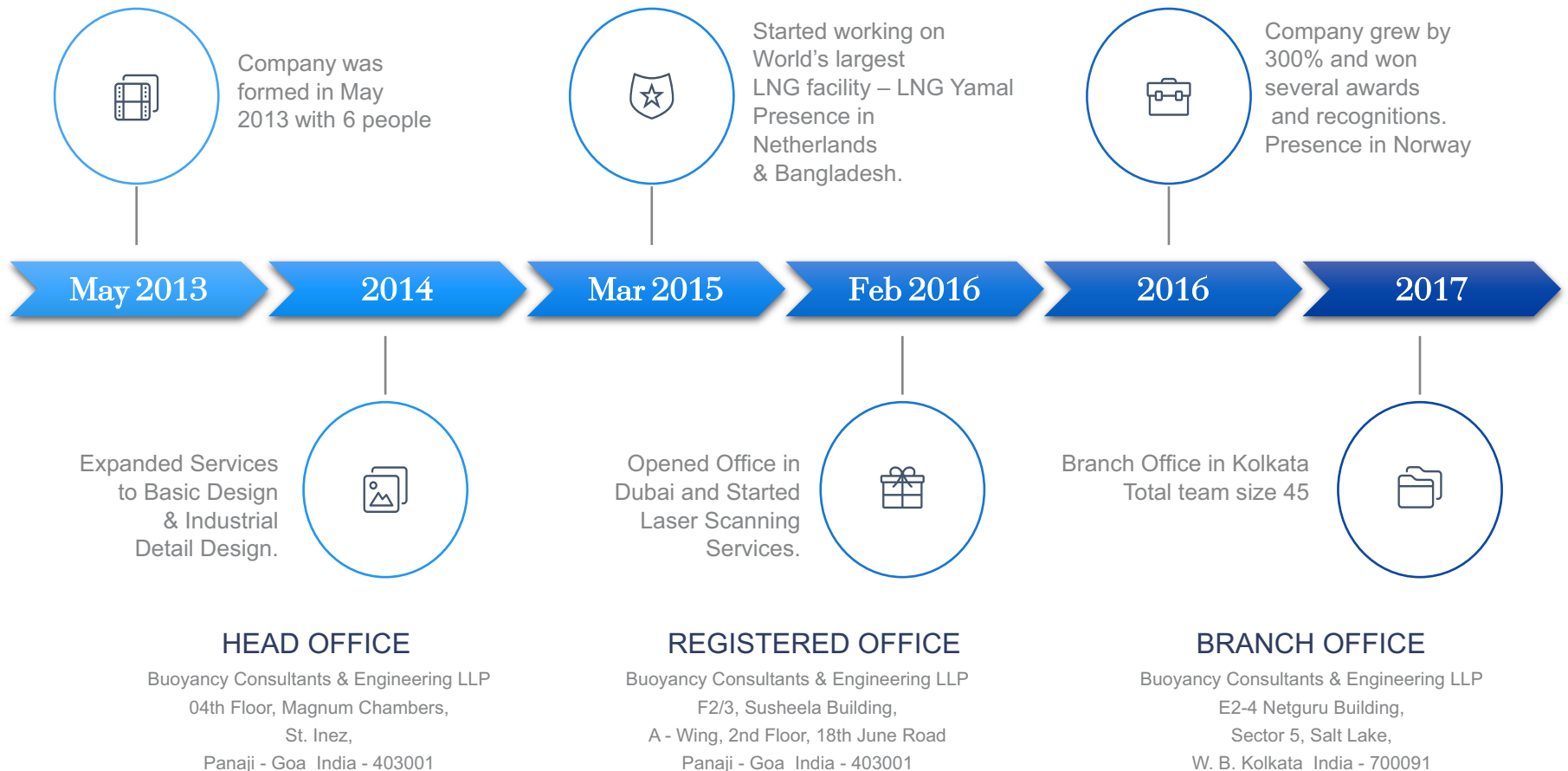

# ACCREDITATIONS & AFFILIATIONS

## MEMBER



## STATUTORY BODIES



CAPTAIN OF PORTS DEPARTMENT  
GOVT. OF GOA

KARWAR PORT AUTHORITY

## CLASSIFICATION BODIES



# STATS

Quality

On Schedule

Customer Experience

97%

## Business Repeat Rate

(Our clients are testament to our standard of Quality & Delivery to their Satisfaction)

10

## Custom Designs

(Solutions for every requirement & situation. We abide by our code : Making your project float!)

18

## Off the Shelf Designs

(Leverage our extensive experience in Onshore and Offshore projects for your immediate needs)

50+

## Projects

Covered across 10 locations worldwide





# PROJECT FLOATED

ACROSS 10 COUNTRIES AND 3 CONTINENTS

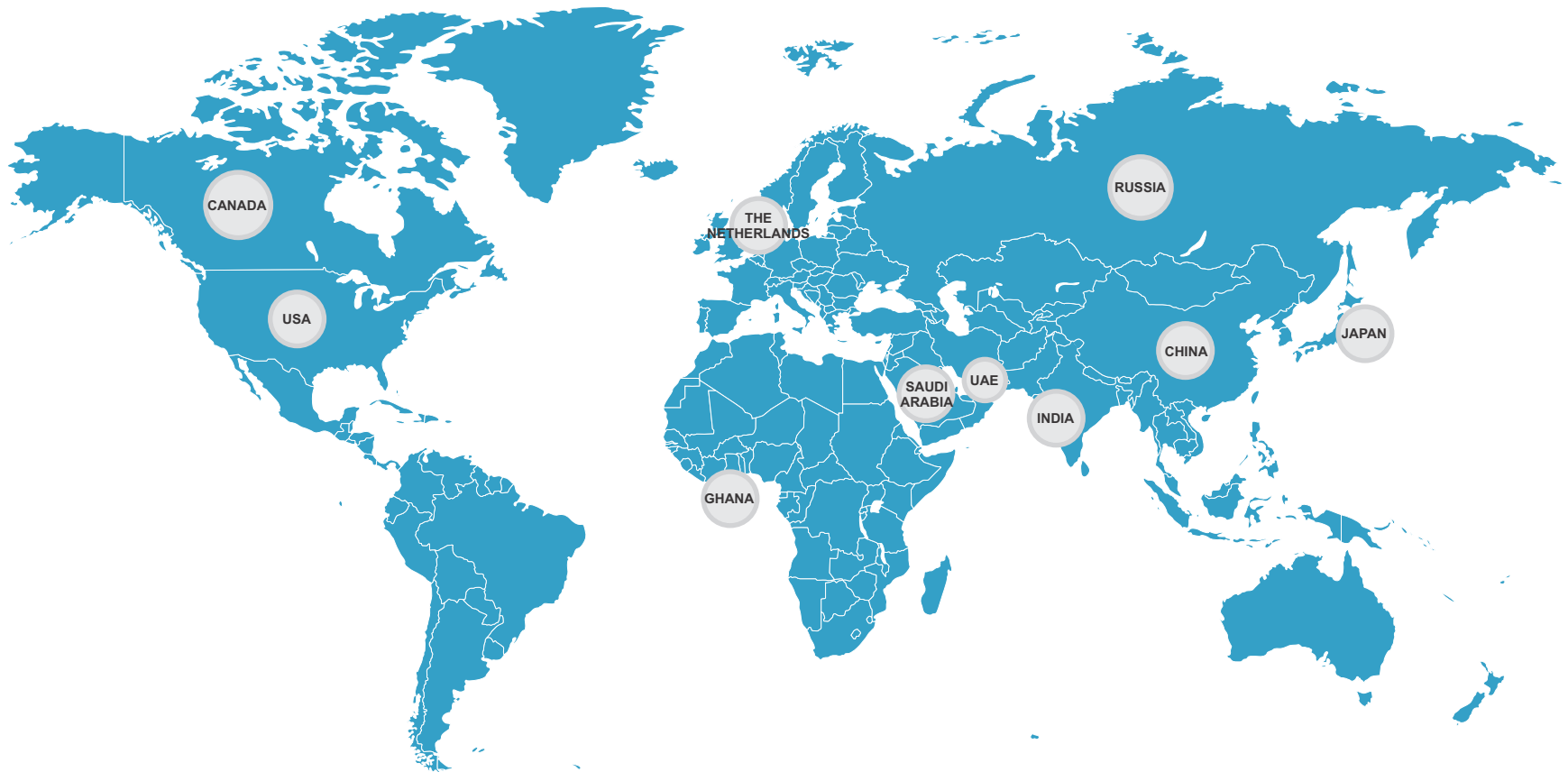

## OUR CLIENTS



